



PARTS LIST

Description	Qty.
1 Trunk Rack	1
2 Drill Template	1
3 Screw, Hex Flange M8 x 16	3
4 Nut, Whizlok M12 - 1.75	1
5 Washer, rubber 1" OD x .50 ID x .125	2
6 Washer, Flat Chrome	3
7 Washer, Rubber 1" OD x .375 ID x .125	6



Tools Needed:
 Scissors (for template)
 Cellophane Tape
 5/8" Hole Saw with Pilot Drill
 Socket, 10mm, with Wrench
 Wrench, 18mm
 Torque Wrench
 Motorcycle Service Manual (for reference)

Attention: Before proceeding with the installation carefully read the instructions and consider whether one possesses the necessary technical skills and workshop tools to complete the installation properly. Otherwise, any BMW Motorcycle Retailer will be glad to install this accessory.

Note: This chrome rack fits to the rear trunk lid of the K1200LT using the same hole locations as the BMW brand plastic luggage rack (BMW No.71-60-7-663-023). If your K1200 trunk lid is not predrilled, use the enclosed template for a drilling guide. If your K1200 lid is predrilled, the holes will need to be opened up to 5/8" or 16mm. (Use a hole saw with pilot drill.)

Note: Chrome Rack Z9050 is fitted with a tail light and wire connector to match Top Case Cable Harness BMW part no. 2305921. If your cable harness is different, it must be retrofitted with the correct harness. Refer to page 2, step no. 7.

PREPARATION

1. Place the motorcycle securely on its center stand or work stand.
2. Remove any trunk rack already installed. Set aside.
3. For predrilled trunk lids, enlarge the drill holes as indicated in the Note above.
4. For lids that are not drilled locate the Drill Template (form No.10-117726-000) and carefully follow the drilling Instructions that follow. Do not attempt to drill the holes without a Drill Template.

DRILLING INSTRUCTIONS TO USE ALONG WITH THE DRILL TEMPLATE

1. Cut out large template along solid bold line.
2. Line up the template front and adjacent sides and tape in positions marked **(1)**
3. Smooth the template and tape positions marked. **(2)**
4. Crease template bottom "V" with fingernail along dashed line.
5. Smooth the template and tape position marked. **(3)**
6. Smooth the template and tape positions marked. **(4)**
7. Cut out measurement template.
8. With measurement template pulled taught check hole positions diagonally.
9. If necessary lift tape positions marked **(4)** and reposition holes H3 and or H4 until diagonal measurement is correct.
10. Drill 1/8" or 3mm pilot hole normal to the surface (as illustrated on the template) at the positions shown.
11. Open the pilot hole to 5/8" or 16mm with a hole saw.

INSTALLATION OF RACK

1. Sort the rubber washers. You should have 2 washers with an ID of .50" and 6 washers with an ID of .375".
2. Install one rubber washer .50 ID onto the threaded leg of the rack. Figure 1.
3. Install one rubber washer .375" ID onto each of the remaining legs. Figure 2.
4. First insert the threaded foot into the lid, and while pushing down to compress the rubber washer you will be able to insert the other three legs. This will require a bit of force but it will pop in without any damage.
3. From the inside of the lid you can place the other rubber washers on the appropriate legs. The plastic lid will be sandwiched between the washers.
4. Install the steel washers along with the 8mm screws on the 3 legs with the .375 washers. **Be sure not to pinch the steel washer between the screw head and the stand-off.**
5. Install the M12 whizlok nut onto the threaded leg.
6. Tighten all fasteners to 5 ft-lbs (7Nm). When properly installed they are engineered to *bottom-out* leaving the correct gap so as not to crush the plastic lid.
7. Connect the electrical wire of the rack into the wire harness in the trunk lid.

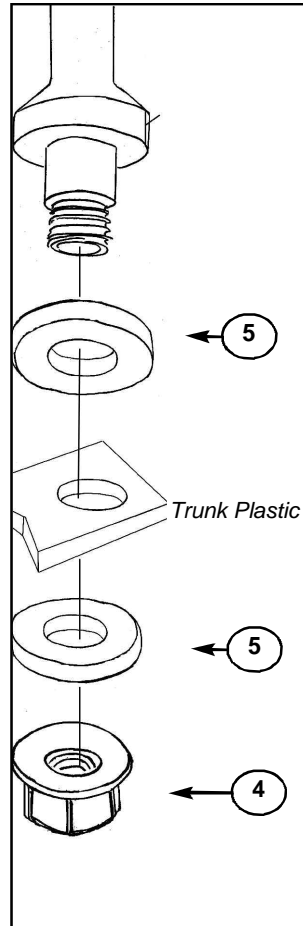

Figure 1.

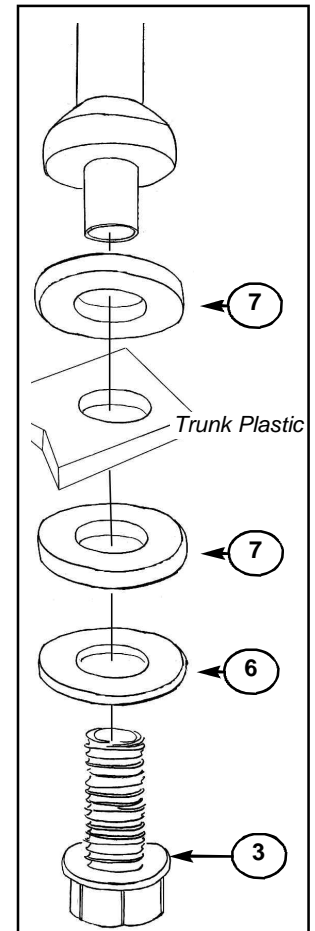

Figure 2.

Note: Chrome Rack Z9050 is fitted with a tail light and wire connector to match Top Case Cable Harness BMW part no. 2305921. Refer to figure 3. If your cable harness is different, your BMW dealer can supply you with the correct cable harness.

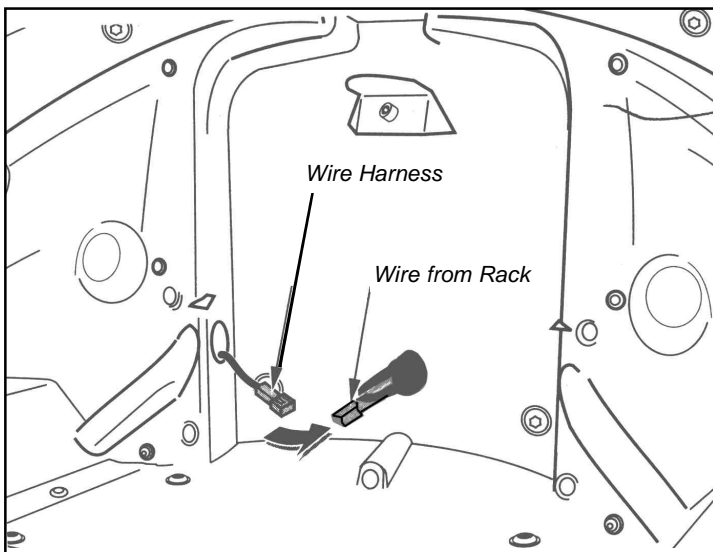

Figure 3. (Inside Trunk Lid)

