



Thank you for purchasing a National Cycle® product. Please read these instructions carefully and thoroughly before beginning work. Dealers if installing this windshield for a customer please give them this manual. It contains information needed to properly maintain and use this product.

Attention



Special notes and cautionary measures which can prevent damage to the accessory or motorcycle.

Note



Tips for facilitation of operation, control and adjustment, as well as maintenance.



T30 Torx Drive
T25 Torx Drive
4mm Hex Wrench

The Left and Right side of motorcycle is determined while sitting on the bike.

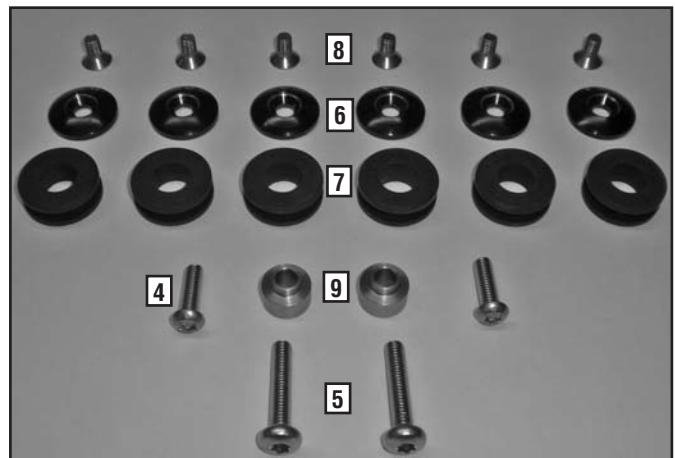

PARTS LIST

Item	Description	Qty.
1	Windshield, Hardcoated Polycarbonate	1
2	37-370224-000 Bracket, Left	1
3	37-370225-000 Bracket, Right	1
BAG #1045		
4	51-516350-000 Screw, M6 x 20 Stainless	2
5	51-516351-000 Screw, M6 x 30 Stainless	2
6	34-346037-000 Cap, Black	6
7	44-447304-000 Grommet	6
8	51-514212-000 Screw, M6 x 12 Stainless	6
9	49-495255-000 Stand Off	2

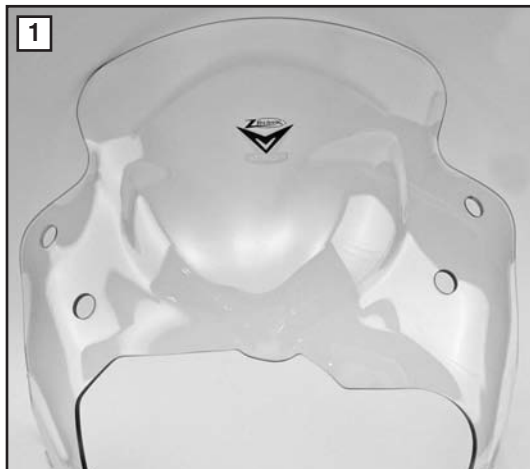
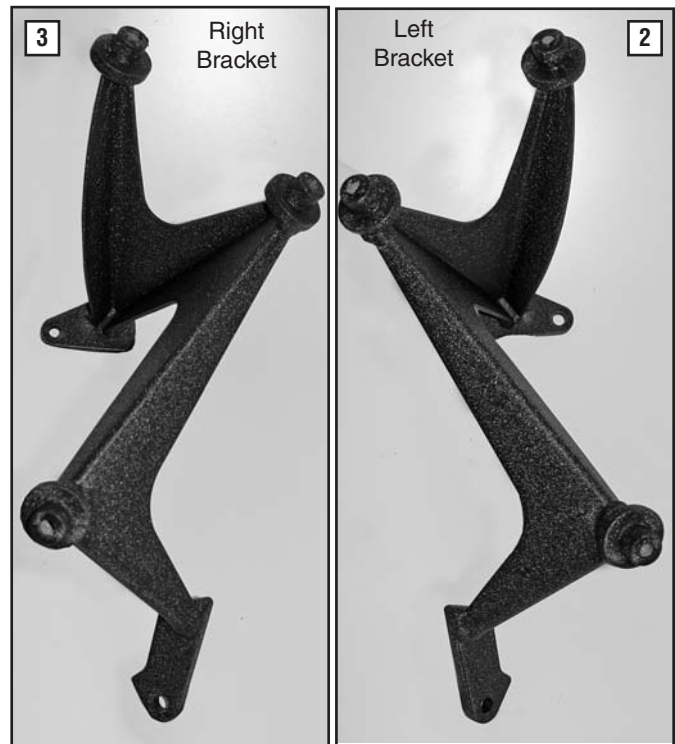

PREPARATION and REMOVAL OF PARTS

Remove the speedometer cowl and wind deflector.

1. Remove the three M5 fasteners holding the deflector in place. (T25 Torx Wrench) **Figure 1.**
2. Remove the deflector.

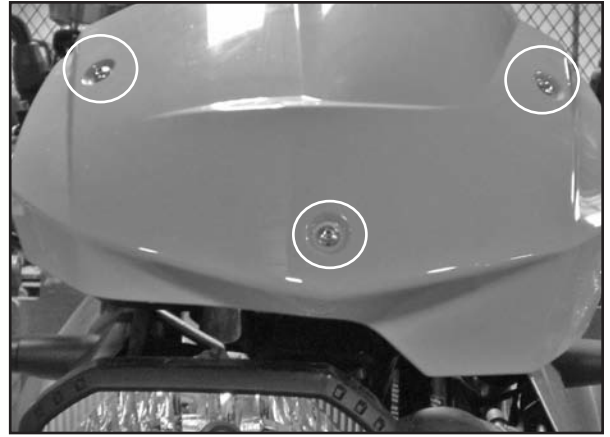

Figure 1

3. Remove the four M6 fasteners located at the bottom of the bracket. (T30 Torx Wrench) **Figure 2**
4. Remove the bracket.

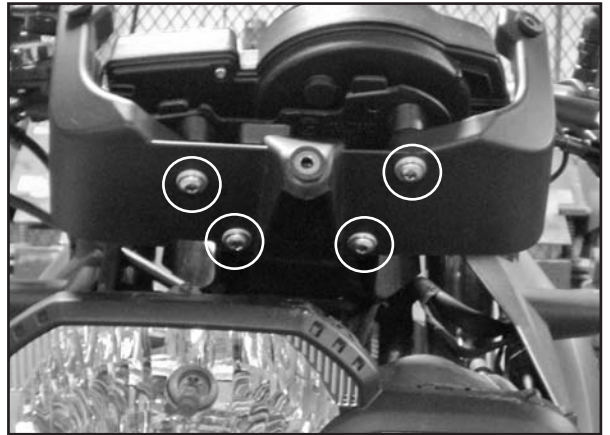

Figure 2

6. Remove the upper and lower headlight/cowl fasteners. (T30 Torx Drive) **Figure 3**



Figure 3

7. Remove the original metal spacers that are pressed into the plastic molding (lower mount only). This part will not be re-used. **Figure 4**

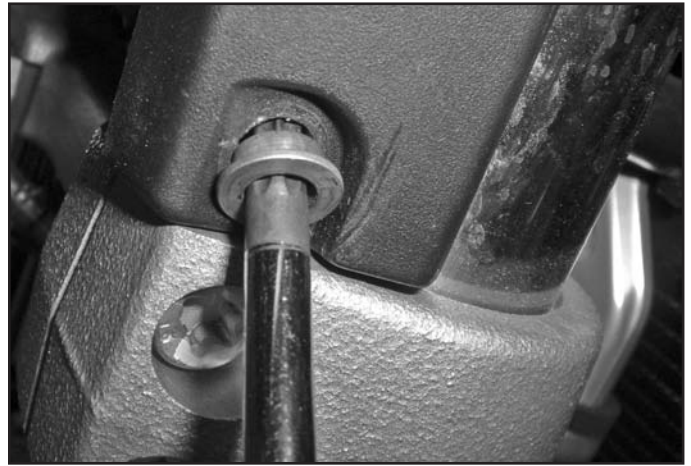

Figure 4

INSTALLATION

1. Separate the left and right side brackets. **(Parts List)**

INSTALL THE BRACKETS

Start on the Left Side of the Motorcycle.

2. Insert the new Stand Off (9) into lower cowl. **Figure 5**

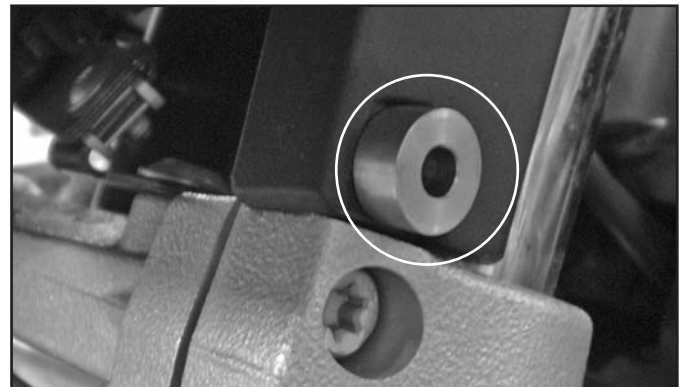

Figure 5

3. Use the M6 x 30mm Screws (5) from Bag 1045 to mount the lower portion of the Left Bracket (2). **(T30 Torx) Figure 6**

4. Pivot the bracket until the upper mounting plate lines up with the top mounting boss.

5. Insure that the **stock metal spacer** is in place at the upper mounting location prior to securing upper mount point on bracket. Use the M6 x 20mm Screw (4) from Bag 1045 and secure the upper mounting point. **(T30 Torx Wrench) Figure 6**

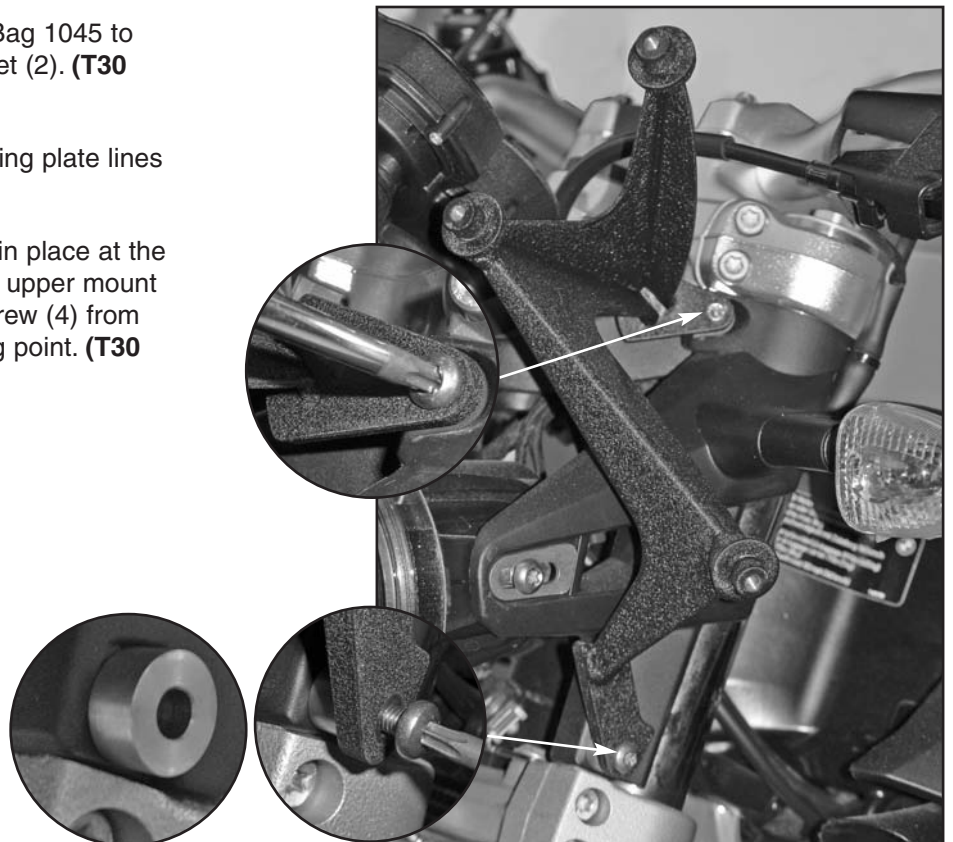



Figure 6

6. Install the right side bracket next. The process is the same, however the top mounting plate must be positioned carefully behind the brake line. **Figure 7 and 8**

7. Tighten all Bracket hardware to manufacturers specification.

INSTALL WINDSHIELD

1. Insert the six rubber grommets into the windshield. **Figure 9**

 Use care in handling the screen while installing shield over brackets.

2. To install the windscreen, straddle the front wheel of the motorcycle while positioning the windscreen near the upper mounting points of the left and right side brackets. Flex the lower portion of the windscreen so that it clears the lower mounting lugs of brackets. (Do not engage the lower mount point at this time). **Figure 10**

3. Align the middle and top grommets with the corresponding lugs on the left and right side brackets. All six mounting points are on different planes, so it is necessary to flex the shield to align all mounting points properly.

4. Align and engage the lower mounting points.

5. Check that all of the six mount holes are properly engaged onto the bracket lugs.



Figure 7



Figure 8



Figure 9



Figure 10

6. Once the shield is positioned, secure the windscreen using the six Caps (6) and the six M6 x 12mm Screws (8) (4mm Hex Wrench) Figure 11

7. Tighten firmly.



Figure 11

MAINTENANCE

To clean the screen, wash with a clean soft cloth, plenty of warm water and if necessary, a non-abrasive soap such as dishwashing liquid. Flannel or soft chamois make good cleaning cloths. **Paint, glue residue or grease removal:** Moisten cotton with Naphtha or Turpentine followed by a wash as above. National Cycle Shield Wash™ makes a good daily cleaner and comes with a handy travel size bottle. N1401 Shield Wash is safe for helmet visors.

Do not clean polycarbonate in hot sun or high temperatures. Do not clean the screen with glass cleaners. Do not use rain protective products on the screen other than National Cycle brand Rain Zip® (Part No. N1410). Do not allow brake fluid, alcohol, or strong solvents to contact the screen.



! WARNING

Never ride your motorcycle with loose accessory mounting hardware. Check the hardware for tightness regularly.

Today's motorcycles are built with enough frame rigidity to withstand the moderate loads imposed on them by the foreseeable addition of an accessory(ies). If an accessory(ies) adversely affects your motorcycle's stability, immediately remove the accessory(ies). Do not ride a motorcycle that exhibits unsafe handling traits.

Have experienced service personnel correct any problem before riding with the accessory(ies) installed. For further questions concerning handling problems associated with an accessory(ies), contact your dealer, motorcycle manufacturer, or accessory manufacturer.



ZTechnik 3-Year Limited Warranty

Register your windshield on Line at: www.ZTechnik.com

ZTechnik hereby warrants to the original registered owner of a ZTechnik polycarbonate windshield for a period of three years from the date of purchase against breakage. This limited warranty is expressly limited to the replacement of the polycarbonate windscreen. This limited warranty does not include scratches, coating failure, cosmetic wear and tear, replacement of hardware, or any consequential damages or expenses including labor cost of installation, removal and/or replacement, inconvenience, inbound freight expenses or damage to any other component of the motorcycle or any other accessories. Certain chemicals, generally known as acidic hydrocarbons, are known to cause polycarbonate damage and will not be covered under this limited warranty. Please refer to the cleaning instructions supplied with all ZTechnik windshields.

Visit www.ZTechnik.com for further details or call or write ZTechnik / PO Box 158 / Maywood, IL 60153 / 708-3430400